

Operation Guide

L100D/L100

(V2.3)

Home & Business Smart Lock



Before Connecting, operating or adjusting this product, please read the instructions completely. Keep this manual you will need it again.

ANVIZ is registered trademark of Anviz Global Inc. in the United States and other countries. It cannot be used without the permission of Anviz.

Before Operation

Note:

1. The lock is equipped with three mechanical keys for manual lock operation. Remove mechanical keys from the package and keep them in a safe place.
2. To power the lock, four alkaline AA batteries (not included) are required. The lock has low battery voltage alarm (Red LED flashes and six beeps when you active the lock) for prompting low battery. Non-alkaline and rechargeable batteries ARE NOT RECOMMENDED.
3. By Default, the lock is configured that ANY fingerprint has access to unlock.
4. By Default, the lock is configured that the lock can not read ID card. Please refer to RFID Card Function to enable card reading function.
5. Please avoid strong light direct to the lock.

Place finger:

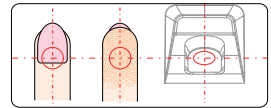

Place finger in the center of the sensor.

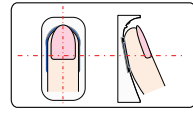

Place finger flat on the sensor surface.

Structure

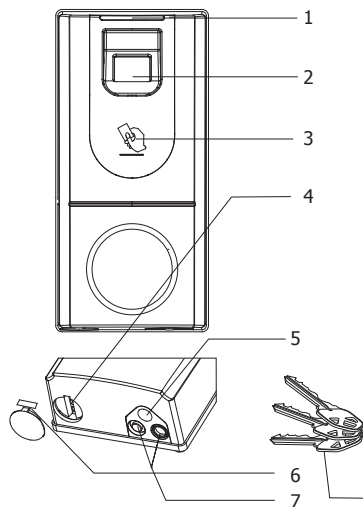

- 1 LED indicator
- 2 Fingerprint sensor
- 3 Card area
- 4 Mechanical key hole
- 5 Restart button
- 6 Rubber cover
- 7 9V Emergency power contact point
- 8 Battery box cover
- 9 Battery area
- 10 Add key
- 11 Delete key
- 12 Nixie tube
- 13 "OK" Confirm Key
- 14 "C" Cancel Key
- 15 Debug Port
- 16 Mechanical key

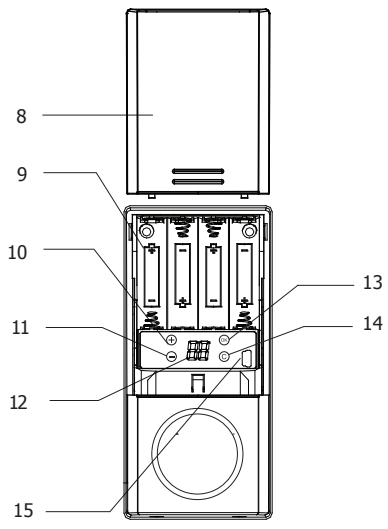

-1-

User Operation

User Introduction

Administrator

This will normally be an official in the company or the host of a family who will have administrator permissions and will be able to do various operations. The lock can set 4 administrators and ID will be 96--99.

Normal user

This will be a user under administrator's management who will be granted access to open the lock. The lock can set 95 normal users and ID number will be 01--95.

The Nixie tube prompting characters

Character	Description
--	Activation status.
Ad	Need administrator identification.
FP	Delete user who is identified by fingerprint or card.
AL	Delete all the users.
01-95	ID range for normal users. (95 users capacity)
96-99	ID range for administrators. (4 administrators capacity)

The Buzzer status

Status	Buzzer	Description
1	Three Beeps	The lock under initial states and be activated.
2	Two Beeps	Enable or Disable work mode.
3	Long Voice	Finger or Card Verification failed.
4	Short music voice	Operation successful.
5	Six beeps	Delete all the user / low battery voltage alarm.

The LED status

Status	LED	Description
1	Bule LED flashes	Activation status.
2	Bule LED fast flashing	Place same finger or swipe same card again.
3	Red LED flashes	Delete user status / low battery voltage alarm.
4	Red LED fast flashing	Place same finger or swipe same card again to delete.
5	Bule and Red LED flashes	Need administrator verify.
6	Red LED light	Unregistered finger or card .

RFID Card Function

RFID Card Function: Enable this function the lock can read ID cards. The battery lifespan can be doubled after disabling the RFID Card Function.

Enable: Verify any registered fingerprint on lock and press **+** key.

Disable: Verify any registered fingerprint on lock and press **C** key.

Normal Open Function

Normal open function: Open the door without fingerprint or card verification on the lock, which is fit for meeting room and some places free to access.

Enable: Verify any registered fingerprints or cards on lock and press **+** key.

Disable: Press **C** key directly.

Initialize The Fingerprint Lock

Initializing the fingerprint lock means all of the user will be deleted and the lock turns back to factory mode.

Operation:

The Initialization Button is in the inside panel of the lock, and holding the Initialization Button until the lock prompts the voice of initialization.

When initialization is completed, the fingerprint lock will restart automatically.

Note: Fingerprint Lock Initialization must be supplied with power.

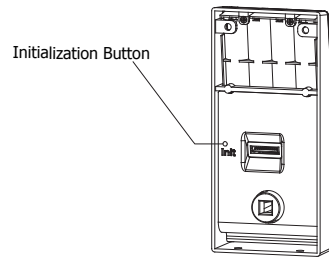

-2-

Quick Operation Mode

Register User (Register user without administrator.)

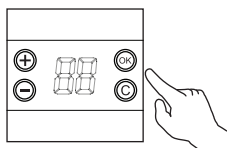

①

Remove the battery box cover. Press any key to activate the lock.

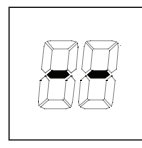

②

The Nixie tube shows "--".

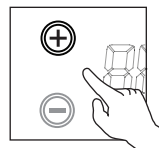

③

Press **+** key.

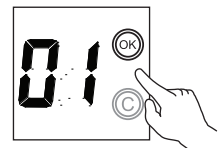

④

The Nixie tube will display normal user ID: 01. Please press **+** and **C** key to select ID and press **+** key to enter the registration status. (User ID range is 01-95)

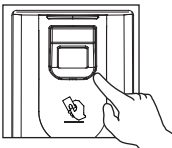

⑤

Place one finger twice on the fingerprint sensor or swipe card on the card area twice.

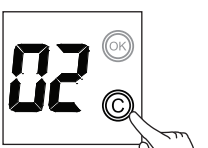

⑥

Next ID number will be displayed after successful registration. Press **+** key to continue register user or press **C** key to exit register status.

* Note:

One ID only can register one fingerprint or one card.

-3-

Delete User (Delete user without administrator.)

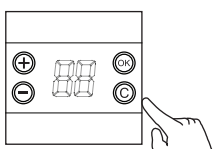

①

Remove the battery box cover. Press any key to activate the lock.

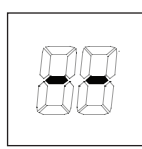

②

The Nixie tube shows "--".

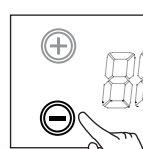

③

Press **-** key.

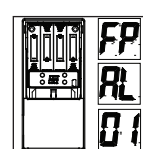

④

When the Nixie tube flashes, please press **+** and **C** key to select "FP", "AL" or "ID" number and press **+** key.



⑤

If "FP" selected, Press **+** key need to place finger twice on the sensor or swipe card twice to delete. Press **+** key to continue delete other users or press **C** key to exit delete status.

If "AL" selected, Press **+** key after six beeps form the lock all of the normal users will be delete. The lock will auto logout deletion status.

If "ID" selected, press **+** key to delete the appointed user. Press **+** key to exit delete status or press **+** and **-** key to continue the deletion of appointed ID.

-4-

Register First Administrator (The first use to register administrator.)



1 Remove the battery box cover. Press any key to activate the lock.

2 The Nixie tube shows "--".

3 Hold **+** key for 3 secs.

4 When it shows admin ID: 96, press **+** or **-** to select ID then **OK** to confirm. (range : 96-99)

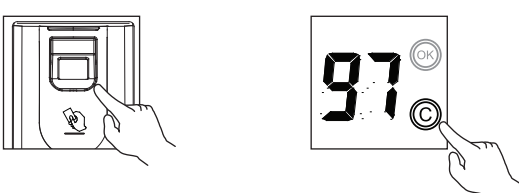

5 Place one Admin finger twice on the fingerprint sensor or swipe card on the card area twice.

6 Next ID number will be displayed after successful registration. Press **OK** to continue register user or press **OK** key to exit register status.

* Note:
One ID only can register one fingerprint or one card.

Register Operators



1 Remove the battery box cover. Press any key to activate the lock.

2 The Nixie tube shows "--".

3 Hold **+** key for 3 secs.

4 Then it shows "Ad".

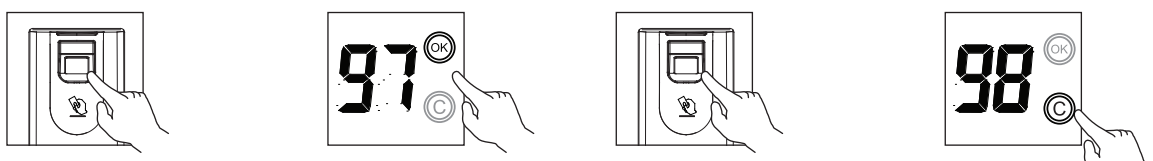

5 Please verify Admin FP or swipe Admin card to enter the registration status.

6 It shows "ID" number, press **+** or **-** key to select ID then press **OK** to confirm.

7 Place one user finger twice on the fingerprint sensor or swipe card on the card area twice (Please enable card function).

8 Next ID number will be displayed after successful registration. Press **OK** to continue register user or Press **OK** key to exit registration status.

Register Normal User



1 Remove the battery box cover. Press any key to activate the lock.

2 The Nixie tube shows "--".

3 Pressing **+** key.

4 Then it shows "Ad".

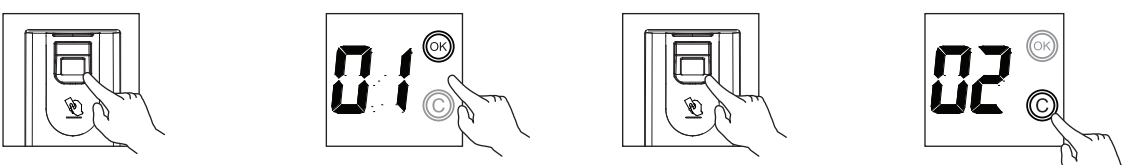

5 Please verify Admin FP or swipe Admin card to enter the registration status.

6 The Nixie tube will display normal user ID: 01. Please press **+** and **-** key to select and press **OK** to enter the registration status. (User ID range: 01-95)

7 Place one finger twice on the fingerprint sensor or swipe card on the card area twice.

8 Next ID number will be displayed after successful registration. Press **OK** to continue register user or press **OK** key to exit register status.

Delete User



1 Remove the battery box cover. Press any key to activate the lock.

2 The Nixie tube shows "--".

3 Press **-** key.

4 Then it shows "Ad".

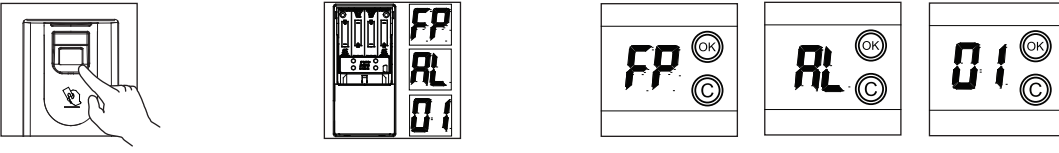

5 Please verify Admin FP or swipe Admin card to enter the registration status.

6 When the Nixie tube flashes, please press **+** and **-** key to select "FP", "AL" or "ID" number and press **OK**.

7 If "FP" selected, Press **OK** key need to place finger twice on the sensor or swipe card twice to delete. Press **OK** key to continue delete other users or press **OK** key to exit delete status.
If "AL" selected, Press **OK** key after six beeps form the lock all of the normal users will be delete. The lock will auto logout deletion status.
If "ID" selected, press **OK** to delete the appointed user. Press **OK** key to exit delete status or press **+** and **-** key to continue select ID number delete the appointed user.

Delete Administrators

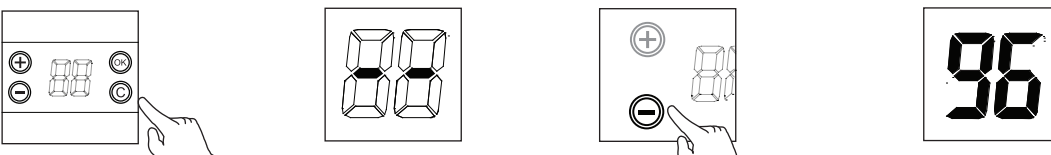

1 Remove the battery box cover. Press any key to activate the lock.

2 The Nixie tube shows "--".

3 Hold **-** key for 3 sec.

4 Then it shows "Ad".

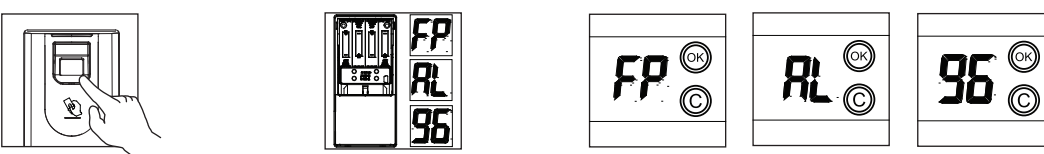

5 Please verify Admin FP or swipe Admin card to enter the registration status.

6 When the Nixie tube flashes please, press **+** and **-** key to select "FP", "AL" or "ID" number. Then press **OK**.

7 If "FP" selected, Press **OK** key need to place administrator finger twice on the sensor or swipe card twice to delete. Press **OK** key to continue delete other administrator or press **OK** key to exit delete status.
If "AL" selected, Press **OK** key after six beeps form the lock all of the administrators will be delete. The lock will auto logout deletion status.
If "ID" selected, press **OK** to delete the appointed administrator. Press **OK** key to exit delete status or press **+** and **-** key to continue the deletion of appointed ID.